

5L Compact Storage Electric Water Heater



Application



Kitchen sink



Bathroom sink/basin

Dimensions

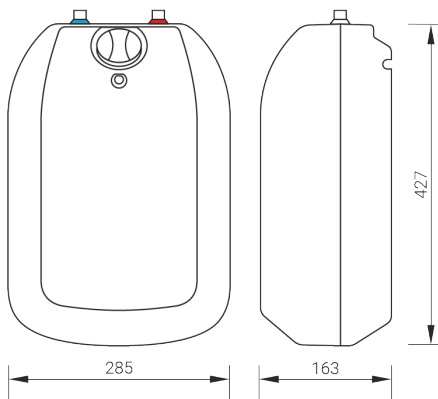

Vented Mixer Tap



Bromic Vented Mixer Tap included with our Bromic Storage Water Heater 5L Underbench kit (HF-UH5)

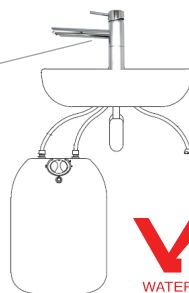

Electronically controlled storage heater, with stainless steel tank designed to ensure quick and easy access to hot water. It is great for installation next to a sink in a laundry, bathroom, or kitchen. This electronic storage hot water heater is energy efficient and compact. The stainless-steel inner tank is resistant to corrosion, with a quick heating time of just 5.5min+ for a full tank.

- **Stainless Steel Tank**
 - + Resistant to corrosion
 - + No need to change anode regularly
- **Comfortable Temperature Control**
 - + With smooth temperature range between 23-70°C
- **Energy Efficient**
 - + With very low energy losses
- **Quick Heating Time**
 - + With immersion heater of 2000W
 - + Heats 5L in 5.5min at 30°C temperature rise
- **Available in under sink & over sink design**
- **For single point of use/outlet**
- **Comes with vented tap. Also available as unit only.**

Model	HF-UH5	HF-OH5
Product No.	2850001	2850002
Mount	Under Sink	Over Sink
Type	Vented Storage	Vented Storage
Voltage, V	240V	240V
Rated Power, kW	2	2
Rated Current, A	8.3 - 9.1	8.3 - 9.1
Max Inlet Pressure Rating, kPa	600	600
Temperature Range, °C	23° - 70°	23° - 70°
Dimensions (H x W x D)	427 x 285 x 163	427 x 285 x 163
Weight, kg	4.5	4.5
IP Rating	IP24	IP24
Water Connections	Cold = G 1/2" Male Hot = G 1/2" Male	Cold = G 1/2" Male Hot = G 1/2" Male
Tank Material	Stainless Steel	Stainless Steel
Approvals	WM 40268 (AS 3498)	WM 40268 (AS 3498)

Download REVIT Files

