

LPG DUAL STAGE REGULATOR LIMITED WARRANTY CONDITIONS

This Limited Warranty provides that those products listed below are warranted against defects in workmanship or materials for the respective periods noted:

- Bromic LPG regulators 1 Year

The Limited Warranty period applies from the date of manufacture (which is evidenced by the date or batch marking on the product). Claims made pursuant to the terms of this Limited Warranty must be made within a reasonable period of the discovery of any defect.

Bromic Pty Ltd's liability in all events is limited (to the extent applicable laws allow) to the purchase price paid for the product or to the repair or replacement of the product (or the defective part or parts of the product) provided that:

- The defects have arisen solely from faulty materials or workmanship
- Before using the product the buyer has determined its suitability for the purpose to which it will be put

Bromic Pty Ltd will not be liable for any indirect or consequential damages or economic loss of any other kind including, without limitation, product losses.

All Bromic LPG regulators must be installed in accordance with Bromic installation instructions and installation will also need to conform with any applicable local, state or national standards. Installation which is not in conformance with those instructions and standards will void the warranty.

This guarantee is expressly in lieu of all other guarantees, warranties, conditions, liabilities or representations in regard to the quality, merchantability or fitness for purpose of the products covered by this Limited Warranty, other than those warranties, conditions, liabilities or representations which are, by reason of any Commonwealth, state or territory legislation, unable to be excluded. However, Bromic Pty Limited's liability pursuant to such statutory rights shall be limited as provided by the terms of this Limited Warranty (to the extent that applicable law allows).

WATER & GAS HOSE ASSEMBLY LIMITED WARRANTY CONDITIONS

This Limited Warranty provides that those products listed below are warranted against defects in workmanship or materials for the respective periods noted:

- Bromic EPDM Core Water Hose assemblies 1 year
- Bromic PEX Core Water Hose assemblies 10 years
- Bromic PEX PRO Water Hose assemblies 15 years
- Bromic Gas Hose assemblies 1 year

The Limited Warranty period applies from the date of manufacture (which is evidenced by the date or batch marking on the hose or ferule). Claims made pursuant to the terms of this Limited Warranty must be made within a reasonable period of the discovery of any defect.

Bromic Pty Ltd's liability in all events is limited (to the extent applicable laws allow) to the purchase price paid for the product or to the repair or replacement of the product (or the defective part or parts of the product) provided that:

- The defects have arisen solely from faulty materials or workmanship
- Before using the product the buyer has determined its suitability for the purpose to which it will be put
- The hose assembly has not had any exposure to heat, corrosive atmosphere or corrosive agents

Bromic Pty Ltd will not be liable for any indirect or consequential damages or economic loss of any other kind including, without limitation, product losses.

All Bromic hose assemblies must be installed in accordance with Bromic installation instructions and installation will also need to conform with any applicable local, state or national standards. Installation which is not in conformance with those instructions and standards will void the warranty.

Refer to the hose label for the tightening requirements of the connector. Ensure not to over tighten the connector. The connector is also subjected to tensile or compressive force and must not be twisted or kinked.

During the installation the water hose assembly is to be installed free from kinks and excessive tight bends. For minimum bend radius (see Table 1). When installing the connector, ensure the bend radius is as large as possible where movement is possible.

DESCRIPTION			MINIMUM BEND RADIUS (Water Hose)					
ID mm	Max: Pressure (MPa)	Temperature	R	A	D (OD)	B	Z a=90	Z a=180
8	1.4	5°C to 70°C	25	25	13	20	140	190
10	1.4	5°C to 70°C	30	30	15	21.5	165	220
19	1.4	5°C to 70°C	55	5	27.5	35	290	396

Table 1: Water Hose installation requirements

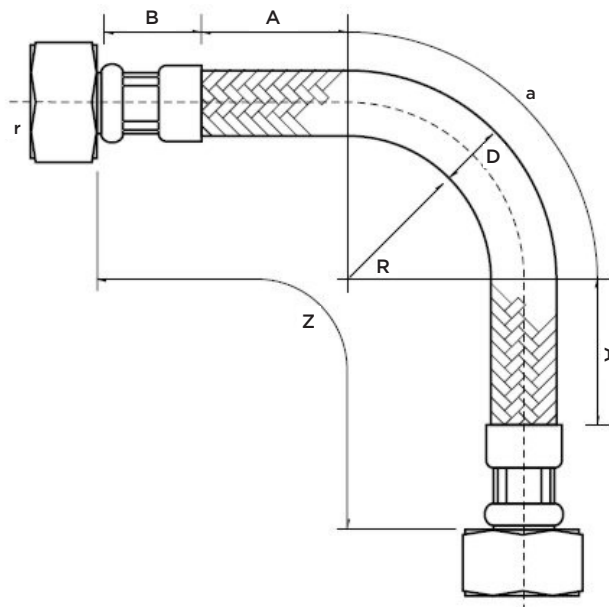

This guarantee is expressly in lieu of all other guarantees, warranties, conditions, liabilities or representations in regard to the quality, merchantability or fitness for purpose of the products covered by this Limited Warranty, other than those warranties, conditions, liabilities or representations which are, by reason of any Commonwealth, state or territory legislation, unable to be excluded. However, Bromic Pty Limited's liability pursuant to such statutory rights shall be limited as provided by the terms of this Limited Warranty (to the extent that applicable law allows).